



Cadet Workbook for Senior Cadet Gap Package

April 2022

Contents

LEADERSHIP ASSIGNMENT PLANNING GUIDE.....	4
PLAN A LESSON CHECKLIST.....	5
LESSON PLAN TEMPLATE	6
POSING QUESTIONS SEQUENCE	8
QUESTIONING TECHNIQUE ACTIVITY	9
SAMPLE LESSON PLAN.....	10
COMPANY FORMATIONS	16
SELECT METHODS OF INSTRUCTION	17
METHODS OF INSTRUCTION.....	18
ACTIVITY PLANNING WORKSHEET	19
LEADERSHIP ASSIGNMENT FORMAT	20
RELAXATION EXERCISES.....	21

WHEN TEAM LEADERS MOTIVATE TEAM MEMBERS

The team leader must motivate team members. The skill of knowing when your team members need to be motivated will develop over time. As a team leader during Gold Star, it is important that you motivate team members at every opportunity.

HOW TEAM LEADERS MOTIVATE TEAM MEMBERS

One of the most common methods used to motivate team members is to use praise. Verbal praise is a very effective way to motivate team members. Verbal praise may be used as positive feedback before, during and at the end of tasks. If possible, team leaders should praise team members in front of others as it makes team members feel valued.

Praising Effort and Perseverance During a Task

It is very important for team leaders to praise team members for their effort and perseverance during a task. Encouraging and caring about team members is an important aspect of being a leader.

Praising the use of Different Strategies During a Task

Team leaders should praise team members when they use different strategies to during a task. Creative thinking is an important tool for leaders.

Praising Improvement During a Task

When team members have completed a task before and they complete the task again more effectively or efficiently, praise should be given. Leaders and team members should always try to improve their performance.

Encouraging the Development of Knowledge and Skills

Team leaders should encourage team members when they learn something new. Everything new that a team member learns may be used at some point to assist the team.

Praising the Completion of a Task

When team members complete a task, praise should be given. It is important to recognize dedication shown in seeing a task through to completion.

Thanking Team Members for Their Endeavours

Team leaders should try to recognize each team member for their contribution in the completion of a task. Making team members feel special is a great way to win even more cooperation from the team.

Giving credit for the completion of tasks to the team rather than yourself

When team leaders are given credit for completing a task, they should ensure that credit is given also to the team members. Recognizing the team for their accomplishments boosts the team's morale.

LEADERSHIP ASSIGNMENT PLANNING GUIDE

ENSURE GOAL

Ask questions to the staff (e.g., where, when to start, how much time)

REQUIRED RESOURCES

What is needed for equipment, how many people, what skills are needed.

MAKE A PLAN

Who is doing what, Reconnaissance of area, etc.

COMPLETE THE TIME APPRECIATION

How long do we have (Time to brief, how long will each part take, debrief)

DIAGRAMS

Will a picture help

PLAN A LESSON CHECKLIST

PREPARATION	NOTES
<p>Have you:</p> <ul style="list-style-type: none"> <input type="checkbox"/> Selected an appropriate lesson location? <input type="checkbox"/> Selected an appropriate method of instruction? <input type="checkbox"/> Provided for a review of previous lesson materials? 	
INTRODUCTION	
<p>Does your introduction:</p> <ul style="list-style-type: none"> <input type="checkbox"/> State what the cadets will learn? <input type="checkbox"/> Describe why the information is important to learn? <input type="checkbox"/> Describe where and when the information / skill can be used? 	
BODY	
<p>Does the body of your lesson:</p> <ul style="list-style-type: none"> <input type="checkbox"/> Include the different principles of instruction? <input type="checkbox"/> Include questions? <input type="checkbox"/> Provide for the use of instructional aids? <input type="checkbox"/> Used explanation and demonstration? (skill lesson only) <input type="checkbox"/> Confirm each TP? 	
END OF LESSON CONFIRMATION	
<ul style="list-style-type: none"> <input type="checkbox"/> Did you conduct an end of lesson confirmation by using questions or by conducting an activity? 	
CONCLUSION	
<p>Does your conclusion:</p> <ul style="list-style-type: none"> <input type="checkbox"/> Summarize the lesson? <input type="checkbox"/> Re-motivate the cadets by: <ul style="list-style-type: none"> <input type="checkbox"/> commenting on their progress; and <input type="checkbox"/> re-stating why the information learned is important? <input type="checkbox"/> Describe the next lesson? 	

LESSON PLAN TEMPLATE

EO #:	Title of the EO:	
Instructor:	Location:	Total Time: min
TIME	REVIEW	NOTES
	EO#: ENABLING OBJECTIVE:	
TIME	INTRODUCTION	NOTES
	What: Where: Why:	
TIME	BODY	NOTES
	Teaching Method: TP 1: TP 1 Confirmation:	

POSING QUESTIONS SEQUENCE

Question Sequence	Action
Pose the question	The instructor must ensure that they have the full attention of the class and ask a question that is clearly heard by all.
Pause	The instructor must allow cadets time to think of a response. Do not waste time, but avoid answering the question for the cadets just to break the silence.
Pounce	When using a direct question, the instructor must indicate which cadet will answer.
Ponder	The instructor must allow the cadets time to answer fully, listen carefully to the response, confirm the correct response and explain why it is correct. If an answer is incomplete, the instructor must emphasize what is correct and ask a follow-up question to complete the response or simply provide additional information. If an answer is incorrect the instructor must point that out as well, in a manner that does not embarrass the cadet and explain why the answer is incorrect. There may be a need to reword the question to get a better response.
Praise	The instructor must praise all cadets for participating and confirm/ summarize all correct responses so as to avoid confusion regarding which responses were correct or incorrect.

PRACTICE

Read the short passage to the group and ask them to remember the children's story "Goldilocks and the Three Bears."

Once upon a time there was a little girl named Goldilocks. She went for a walk in the forest. Pretty soon, she came upon a house. She knocked and, when no one answered, she walked right in.

Use the questions below to have each cadet use the question posing sequence at least once.

Q. Who do you think lived in the house in the forest?

A. The three bears.

Q. What did Goldilocks first do when she entered the house?

A. She tasted the porridge.

Q. Whose chair did Goldilocks break?

A. Little bear's chair.

Q. Why did Goldilocks go upstairs to the bedroom?

A. She felt tired.

Q. Did Goldilocks ever return to the house in the forest?

A. No.

QUESTIONING TECHNIQUE ACTIVITY

Draw a line from the question to the matching P in questioning technique.

Sgt Timbers, have you finished your fitness evaluation test?

Lead-off

Sgt Wood, you are correct about the part you need 16 curl ups but you have the push up amount wrong. Can anyone tell

us how many push ups are needed?

Follow-up

Ok Cadets! Where do I find IG's for lesson plans?

Direct

I will give you a minute to answer this question. Who is our commanding Officer?

Overhead

SAMPLE LESSON PLAN

EO #: M308.02	DELIVER WORDS OF COMMAND
---------------	--------------------------

Instructor:	Location: CLASSROOM	Total Time:	30 min
-------------	---------------------	-------------	--------

TIME	REVIEW	NOTES
------	--------	-------

2.5 min	M308.01 - Prepare a Squad for Parade	Ask Questions
---------	---------------------------------------------	---------------

TIME	INTRODUCTION	NOTES
------	--------------	-------

2.5 min	<p>What: In this class you will learn the parts of a command, and what it takes to deliver commands well.</p> <p>Why and Where:</p> <p>It is important for cadets to know how to deliver words of command. Words of command that are delivered in a clear and concise manner, with confidence and determination, will affect how cadets respond to orders. Words of command are required to move a group in an organized and efficient manner.</p>	
---------	------------------------------------------------------------------------------------------------------------------------------------------------------------------------------------------------------------------------------------------------------------------------------------------------------------------------------------------------------------------------------------------------------------------------------------------------------------------	--

TIME	BODY	NOTES
------	------	-------

10 min	<p><u>Teaching Point 1 – Parts of a command</u></p> <p>Identifying the two parts of a command is easily done by writing this example for students to see. Then, demonstrating the execution of this simple command using your voice.</p> <p>CAUTIONARY COMMAND</p> <p>A cautionary command shall be given at the beginning of every command to warn the squad that a movement will be performed.</p>	
--------	--------------------------------------------------------------------------------------------------------------------------------------------------------------------------------------------------------------------------------------------------------------------------------------------------------------------------------------------------------------------------------------------------------------------	--

It includes additional instructions to the command such as “advance” or “retire”. The direction of the movements are indicated based on the initial front rank.

The additional instructions are based on the direction a squad falls in.

In general:

- Advance. Indicates a turn or movement in the direction of the front rank (is used whenever turning into line).
- Retire. Indicates a turn or movement in the direction of the rear rank (is used whenever turning into line).
- Move to the Right/Left. Indicates a turn or movement in the direction of the indicated flank (e.g., the right/left markers).

EXECUTIVE COMMAND

An executive command is to signal that the movement is to be carried out. When written, a dash shall separate the cautionary command from the executive command.

The following are examples of words of command. In these examples, the word “TURN” indicates the executive command.

•“SQUAD RETIRE, RIGHT—TURN,”•“SQUAD ADVANCE, LEFT—TURN,” and

•“SQUAD MOVE TO THE RIGHT IN COLUMN OF ROUTE, RIGHT—TURN.”

On the march, the cautionary command should be drawn out over at least two paces of quick time and the interval between the cautionary and executive commands should be two paces.

Putting it together

Example:

SQUAD, MOVE TO THE RIGHT IN THREES, RIGHT – _TURN

[_____ Cautionary _____] - [Executive]

Cautionary (Who) – Squad, Platoon, Flight, Corps, Squadron

Cautionary (Information): Advance, Retire, Direction, Form

Executive (When): The signal to do the movement

Notes:

The Dash (-) is the pause in delivery of the command to add emphasis on the executive.

Tips: Always plan what you're going to say in your mind before it comes out your mouth.

If you say the wrong command, correct it immediately by say, "As You Were." Then give the correct command. If you are given an incorrect command (ex. You're standing at attention and someone commands you to attention), do not move.

QUESTIONS

Q1. Why are cautionary commands given?

Q2. What is the purpose of the executive command?

Q3. When commands are written, what is the purpose of the dash?

ANTICIPATED ANSWERS

A1. To warn the squad that a movement will be performed.

- A2. To signal that the movement is to be carried out.
- A3. To separate the cautionary from the executive command

10 Min

TEACHING POINT 2 - Demonstrate and Explain the Requirements for a Well-Delivered Command

As each point is discussed, give an example of a command being delivered correctly and incorrectly, using the specified technique.

VOICE – *The voice used to deliver commands has a strong effect on how others will respond.*

Consider the following:

- a. **Volume** – adjust based on number of individuals and other circumstances (marching or overtop of a band)
- b. **Projection** – message must reach a desired distance. Posture, breathing, relaxed throat and open mouth will help project voice project efficiently
- c. **Distinctness** – clear pronunciation
- d. **Inflection** – change of pitch in voice between cautionary and execution of your command. Execution portion has higher pitch than the cautionary portion
- e. **Snap** – Expressing confidence, decisiveness and importance of a command

ACCURACY – *Correct words and voice will deliver the best message when giving commands. Commands delivered on the march must be given on the correct foot.*

CONFIDENCE – *This portrays that an order given must be promptly and smartly obeyed. Commands delivered with confidence will build a sense of security within members of the squad*

CORRECT POSTURE – Allows proper breathing from the diaphragm providing more volume and projection. Maintain a straight back and keep shoulders back when delivering commands

BREATHING CONTROL – Breath deep and relaxing the muscles in your neck and vocal cords will provide more control and higher volume. Also allows your voice to be projected from the diaphragm instead from your throat.

QUESTIONS

Q1. If a command is not pronounced clearly and distinctly, what affect may it have on the squad being commanded?

Q2. Why should commands be delivered with confidence?

Q3. How does poor posture affect delivering commands?

ANTICIPATED ANSWERS

A1. Cadets may not understand the command and perform the wrong movement.

A2. It portrays that it is an order that must be promptly and smartly obeyed.

A3. It restricts the ability to breathe deeply, restricting the movement of the diaphragm, which will cause commands to come from the throat.

TIME	CONFIRMATION	NOTES
5 Min	<p><u>Activity</u></p> <p>Divide your cadets into two groups and have them take up a position on opposite sides of your work area (classroom or parade square).</p> <p>Advise one group 1, they will be giving commands to group 2. Group 2 will be critiquing the commands they receive by providing constructive feedback. Then the groups will switch roles.</p> <p>This activity will act as the confirmation of the lesson taught.</p>	
TIME	CONCLUSION	NOTES
2.5 Min	<p>Closing Statement:</p> <p>When words of command are delivered in a clear and concise manner and with confidence and determination, it will affect how cadets respond to the order.</p> <p>Your next period will be _____</p>	

COMPANY FORMATIONS

General

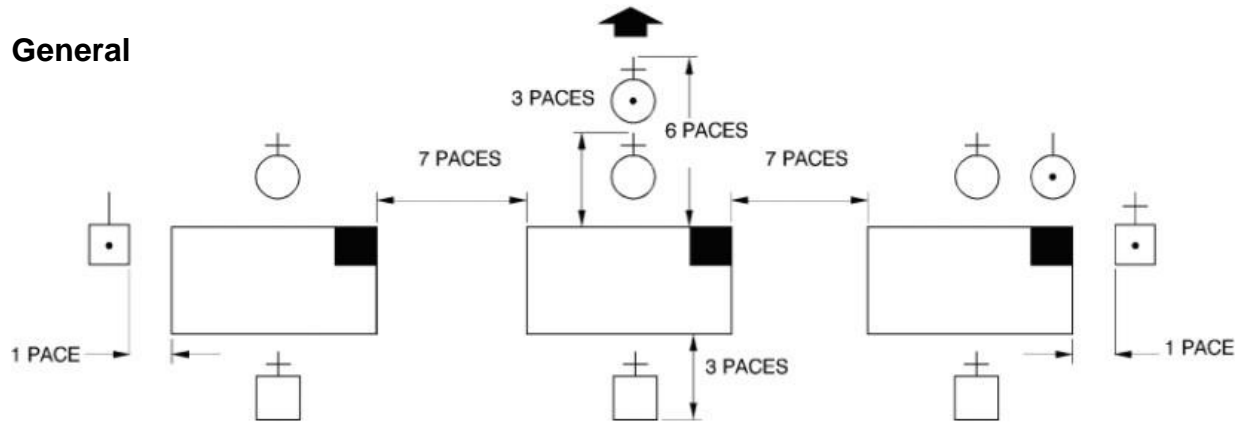

Company in Column of Threes

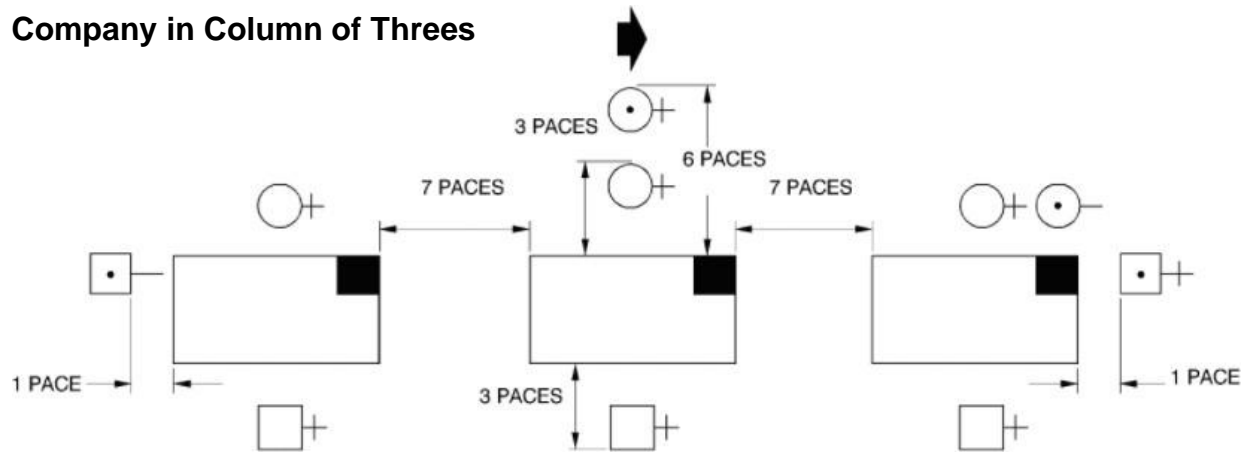

Company in Column of Route

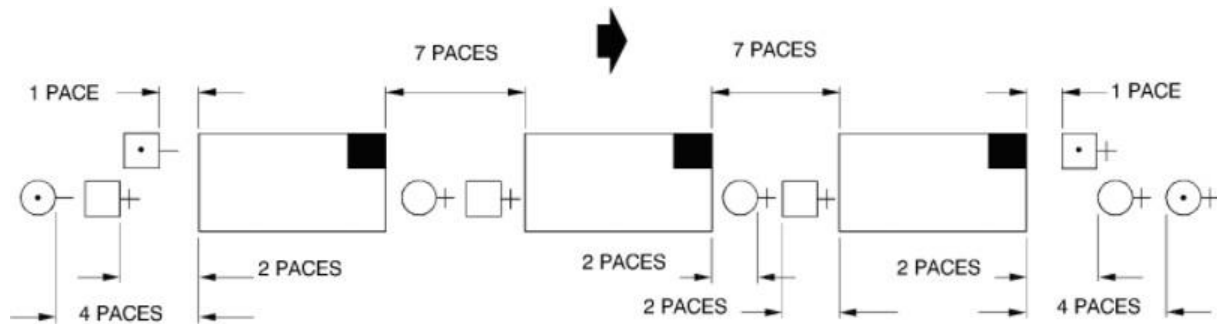

SELECT METHODS OF INSTRUCTION

Lesson Topic	Method of Instruction	Explanation
Participate in a Discussion on Hygienic Practices		
Identify the Parts and the of the Daisy 853C Air Rifle		
Apply Basic Marksmanship Techniques		
Participate in a Discussion on Proficiency Level One Training		
Wear the Air Cadet Uniform		
Participate in a Discussion of Year One Summer Training Opportunities		
Construct a Lean-to-Style Shelter		
Operate a Handheld Radio		
Invent a Space Technology Item		
Discuss Leadership Within a Peer Setting		
Identify Year Three CSTC Training Opportunities		
Fly a Paper Colditz Glider		
Identify the Rank Structure of the Sea, Army and Air Cadets		

METHODS OF INSTRUCTION

<p>Guided Discussion.</p> <p>The instructor guides students in steps to reach instructional objectives by drawing out their opinions, knowledge, experience and capabilities and then building on them to explore and develop new material.</p>	<p>Demonstration and Performance.</p> <p>Used primarily when teaching specific skills. Instructors explain then demonstrate the skill to be performed, students practice under supervision.</p>	<p>Interactive Lecture.</p> <p>A formal or semi-formal presentation in which the instructor presents a series of events, facts or principles. Students listen and participate by asking or responding to questions, discussing the material being presented</p>	<p>Games.</p> <p>Effective when trying to keep students interested in the lesson and the material</p> <hr/> <p>Experiential Learning.</p> <p>Involves learning knowledge and skills from direct experience.</p>
<p>Group Discussion.</p> <p>Students discuss issues, share knowledge, opinions and feelings about a topic in groups to meet a specified goal.</p>	<p>On the Job Training.</p> <p>Prepares students to perform a job. Students learn job related behaviors/skills and practice them through performance of the job.</p>	<p>Problem-based Learning.</p> <p>Students analyze a problem, apply the steps in the problem-solving method, and work toward solving the problem in small groups.</p>	<p>Field trips.</p> <p>Permit students to observe “real life” operations, demonstrating the relevance of theory taught in the classroom in the actual environment.</p>
<p>Role playing exercises.</p> <p>Students can play out and practice responses to realistic situations similar to those they would encounter in real life, in a controlled environment</p>	<p>Self-Study.</p> <p>The instructor provides materials and instructions to the students and the students then learn the topic independently.</p>	<p>Tutorial.</p> <p>The instructor works directly with a student, teaching complex skills, knowledge and procedures, or to provide remedial training</p>	<p>Case Study.</p> <p>Students are provided with the opportunity to deal with simulated, real-life situations in the classroom environment through a scenario.</p>

ACTIVITY PLANNING WORKSHEET

Activity: _____

Total Time: _____

INTRODUCTION		Time
Warm-up <i>(if applicable)</i>		
Recap of Previous Activity <i>(if applicable)</i>		
Activity Overview		
BODY		Time
Activity Breakdowns <i>(if applicable)</i>		
Logistics <i>(equipment, facilities, personnel, etc.)</i>		
CONCLUSION / DEBRIEF		Time
Recap Activity Goals		
Cool-Down <i>(if applicable)</i>		
Tear-down and Secure Equipment		

Notes / Comments:

LEADERSHIP ASSIGNMENT FORMAT

1. Prepare for the leadership assignment by:
 - a. ensuring the goal is understood;
 - b. ensuring the required resources are available;
 - c. completing a time appreciation; and
 - d. making a plan.
2. Introduce the leadership assignment by:
 - a. stating the assignment to be completed;
 - b. stating the goal of the assignment;
 - c. identifying the resources required for the assignment;
 - d. communicating the overall plan;
 - e. assigning tasks to team members as applicable; and
 - f. ensuring the team members understand the assignment.
3. Conduct the leadership assignment by:
 - a. supervising peers;
 - b. maintaining team control;
 - c. ensuring the assignment is progressing according to the time allotted; and
 - d. modifying the plan as required.
4. Debrief the team following the leadership assignment by:
 - a. reviewing the goal;
 - b. providing feedback; and
 - c. re-motivating the team.
5. Complete an after-assignment report and a self-assessment.
6. Attend a debriefing with the directing staff

RELAXATION EXERCISES

RELAXATION EXERCISES

Rag Doll

1. Sit in a chair (or stand) with feet apart.
2. Stretch the arms and trunk upward and inhale.
3. Exhale and drop the body forward. Let the trunk, head and arms dangle between the legs, keeping the muscles relaxed (as illustrated in Figure 1).
4. Remain in this position for 10–15 seconds.
5. Slowly roll up, one vertebrae at a time.



Figure A-1 Rag Doll

Note. From Fitness for Life: Updated Fifth Edition (p. 300), by C. Corbin, & R. Lindsey, 2007, Windsor, ON: Human Kinetics. Copyright 2007 by The Cooper Institute.

Neck Roll

1. Sit in a chair or on the floor with legs crossed.
2. Keeping the head and chin tucked, inhale and slowly turn the head as far left as possible (as illustrated in Figure 2).
3. Exhale and turn the head to the centre.
4. Repeat steps 2–3 for the right side.
5. Repeat steps 2–4 three times, trying to turn further each time to feel the stretch in the neck.
6. Drop the chin to the chest and inhale while slowly rolling the head in a semicircle to the left shoulder and exhale while slowly rolling the head back to the centre.
7. Repeat step 6 for the right side.



Figure A-2 Neck Roll

Note. From Fitness for Life: Updated Fifth Edition (p. 300), by C. Corbin, & R. Lindsey, 2007, Windsor, ON: Human Kinetics. Copyright 2007 by The Cooper Institute.

Body Board

1. Lie on the right side with arms over the head (as illustrated in Figure 3).
2. Inhale and stiffen the body like a wooden board.
3. Exhale and relax the muscles and collapse.
4. Let the body fall without trying to control the direction (as illustrated in Figure 4).
5. Lie still for ten seconds.
6. Repeat steps 1–5 for the left side.



Figure A-3 Body Board Start Position

Note. From Fitness for Life: Updated Fifth Edition (p. 301), by C. Corbin, & R. Lindsey, 2007, Windsor, ON: Human Kinetics. Copyright 2007 by The Cooper Institute.



Figure A-4 Body Board Finish Position

Note. From Fitness for Life: Updated Fifth Edition (p. 301), by C. Corbin, & R. Lindsey, 2007, Windsor, ON: Human Kinetics. Copyright 2007 by The Cooper Institute.

Jaw Stretch

1. Sit in a chair or on the floor with head up and arms and shoulders relaxed.
2. Open mouth as wide as possible and inhale.
3. Relax and exhale slowly.
4. Shift the jaw to the right as far as possible and hold for three seconds (as illustrated in Figure 5).
5. Repeat step 4 for the left side.
6. Repeat steps 4–5 ten times.

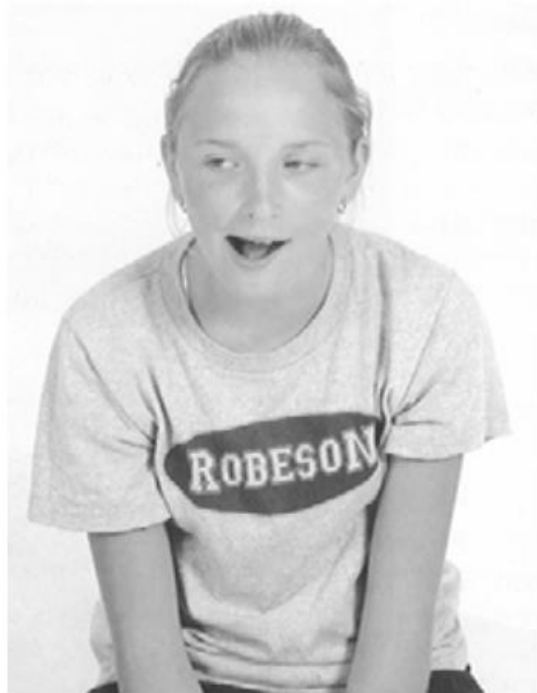

Figure A-5 Jaw Stretch

Note. From *Fitness for Life: Updated Fifth Edition* (p. 301), by C. Corbin, & R. Lindsey, 2007, Windsor, ON: Human Kinetics. Copyright 2007 by The Cooper Institute.